

Technical data sheet



Product features

Cooking range combined with static electric oven GN 2/1 - 6x burner ECO

Model	SAP Code	00110109
--------------	-----------------	----------



- Device type: Combined unit
- Power consumption of the zone 1 [kW]: 6
- Power consumption of the zone 2 [kW]: 6
- Power consumption of the zone 3 [kW]: 6
- Power consumption of the zone 4 [kW]: 6
- Power consumption of the zone 5 [kW]: 3,5
- Power consumption of the zone 6 [kW]: 3,5
- Type of internal part of the appliance 1 (eg oven): Electric
- Type of internal part of the appliance 2 (eg oven): Static
- Material: AISI 304 top plate, AISI 430 cladding

SAP Code	00110109	Power consumption of the zone 2 [kW]	6
Net Width [mm]	1200	Power consumption of the zone 3 [kW]	6
Net Depth [mm]	700	Power consumption of the zone 4 [kW]	6
Net Height [mm]	900	Power consumption of the zone 5 [kW]	3,5
Net Weight [kg]	115.00	Power consumption of the zone 6 [kW]	3,5
Power electric [kW]	6.300	Type of internal part of the appliance 1 (eg oven)	Electric
Loading	400 V / 3N - 50 Hz	Type of internal part of the appliance 2 (eg oven)	Static
Power gas [kW]	31.000	Width of internal part [mm]	682
Type of gas	Natural gas, propane butane	Depth of internal part [mm]	558
Number of zones	6	Height of internal part [mm]	348
Power consumption of the zone 1 [kW]	6	Diameter of device [mm]	100

Technical data sheet



Technical drawing

Cooking range combined with static electric oven GN 2/1 - 6x burner ECO

Model	SAP Code	00110109
--------------	-----------------	----------

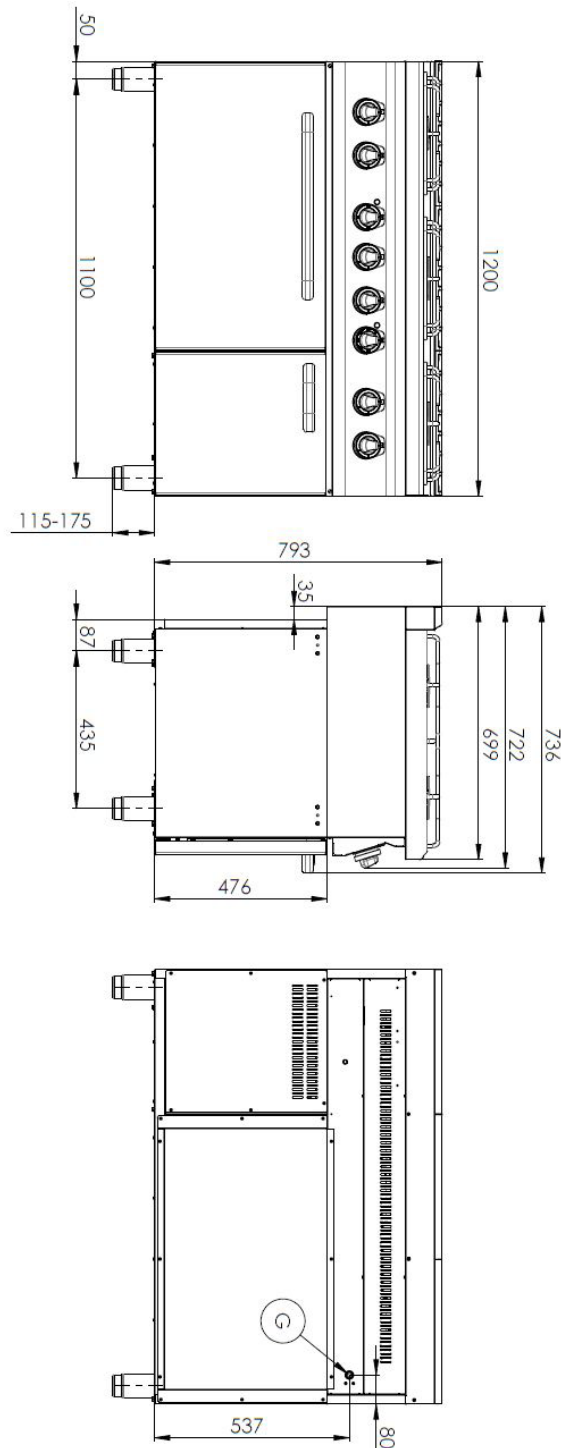

Cooking range combined with static electric oven GN 2/1 - 6x burner ECO

Model	SAP Code	00110109
--------------	-----------------	----------

1

Massive construction of burners

- high performance and efficiency
- cast iron burners removable
- long life
 - energy saving (perfect combustion)
 - time saving for food preparation
 - easy maintenance/cleaning

2

Hygienic moldings of the top plate

- absence of sharp corners and edges (potential places where dirt could stick)
- smooth transitions
 - easy quick cleaning

3

Degree of protection of the control elements IPX4

- maintenance-free system
- resistance to splash water
- long life
 - savings on service interventions
 - easy cleaning and maintenance of equipment

4

All-stainless design

- long life
- resistance of a ground steel plate with a thickness of 10 mm
 - savings on service interventions
 - higher corrosion resistance

5

Safety element – thermocouple

- safe operation for personnel
- there is no overheating and damage to the thallus
- long life
 - savings on service interventions
 - easier and faster operation

6

Large electric oven with four positions for racks with static cooking

- possibility of baking
- high capacity and variability
- all-stainless design
 - suitable for yeast dishes and desserts
 - long service life
 - easy to clean

Technical data sheet



Technical parameters

Cooking range combined with static electric oven GN 2/1 - 6x burner ECO

Model	SAP Code	00110109
--------------	-----------------	----------

1. SAP Code:

00110109

2. Net Width [mm]:

1200

3. Net Depth [mm]:

700

4. Net Height [mm]:

900

5. Net Weight [kg]:

115.00

6. Gross Width [mm]:

1240

7. Gross depth [mm]:

800

8. Gross Height [mm]:

975

9. Gross Weight [kg]:

132.00

10. Device type:

Combined unit

11. Construction type of device:

With substructure

12. Power electric [kW]:

6.300

13. Loading:

400 V / 3N - 50 Hz

14. Power gas [kW]:

31.000

15. Type of gas:

Natural gas, propane butane

16. Material:

AISI 304 top plate, AISI 430 cladding

17. Worktop material:

AISI 304

18. Worktop Thickness [mm]:

1.20

19. Number of zones:

6

20. Power consumption of the zone 1 [kW]:

6

21. Power consumption of the zone 2 [kW]:

6

22. Power consumption of the zone 3 [kW]:

6

23. Power consumption of the zone 4 [kW]:

6

24. Power consumption of the zone 5 [kW]:

3,5

25. Power consumption of the zone 6 [kW]:

3,5

26. Number of power control stages:

6

27. Safety thermostat up to x ° C:

360

28. Adjustable feet:

Yes

Technical data sheet



Technical parameters

Cooking range combined with static electric oven GN 2/1 - 6x burner ECO

Model	SAP Code	00110109
--------------	-----------------	----------

29. Number of burners/hot plates:

6

30. Diameter of device [mm]:

100

31. Type of gas cooking zones:

Cast iron burners

32. Type of internal part of the appliance 1 (eg oven):

Electric

33. Type of internal part of the appliance 2 (eg oven):

Static

34. Width of internal part [mm]:

682

35. Depth of internal part [mm]:

558

36. Height of internal part [mm]:

348

37. Maximum temperature of the inner chamber [°C]:

300

38. Minimum temperature of the inner chamber [°C]:

50

39. Connection to a ball valve:

1/2

40. Cross-section of conductors CU [mm²]:

1

- Výkon (kW): 3,7-5 (230 V); 6,4-8,7 (400 V)